

and conductivity<sup>13</sup> established that **1**<sub>6</sub>Oct forms an aggregate at  $1.6 \times 10^{-4}$  M (at 30 °C). Thus, the kinetic measurements were carried out below this concentration. On the other hand, the aggregate formation was not found up to 0.2 M for **1**<sub>4</sub>Me and **1**<sub>6</sub>Me. The progress of the hydrolysis reaction (30 °C) was followed spectrophotometrically by monitoring the increase in the absorption band (401 nm) of *p*-nitrophenolate.

In the basic hydrolysis of pNPD (30 °C, 0.10 M NaOH) with *p*-methoxy-*N,N,N*-trimethylanilinium chloride (**2**) as a reference molecule to **1**<sub>4</sub>Me, a plot with an upward  $k_{\text{obsd}}$  vs [2] curvature was obtained (similar to Figure 3 in ref 4:  $k_{\text{obsd}} = (4-10) \times 10^{-3}$  s<sup>-1</sup> at [2] = 0.03-0.2 M). The plot of  $\log k_2 (= k_{\text{obsd}}/[\text{OH}^-])$ : second-order rate constant vs [2] gave a good linear relationship ( $r = 0.998$ ). From the slope MH was estimated to be 1.25, which is comparable with those of *N,N,N*-trimethylanilinium iodide (1.48) and *N,N,N*-trimethylbenzylammonium iodide (1.60) determined by Menger and Venkataram at 25 °C.<sup>4</sup> As shown in Figure 1, the plot for **1**<sub>4</sub>Me curved upward, indicating that the "desheilding" mechanism is operative in **1**<sub>4</sub>Me-mediated basic hydrolysis. The plot of  $\log k_2$  vs [**1**<sub>4</sub>Me] gave a good linear relationship ( $r = 0.999$ ) with MH = 33.4. This value is larger by a factor of 26.7 than that for **2**. The MH value per a phenol unit of **1**<sub>4</sub>Me ( $33.4/4 = 8.35$ ) is still larger by a factor of 6.7, indicating that the polycationic macrocycle exerts the "desheilding" effect much more effectively than the monocationic ammonium salt.

Interestingly, we found that in the presence of **1**<sub>6</sub>Me or **1**<sub>6</sub>Oct the rate of basic hydrolysis in 0.1 M NaOH was too fast to follow by conventional spectroscopic methods. Therefore, we determined the rate constants at pH 8.51. It is seen from Figure 1 that (i) the reaction proceeds according to the Michaelis-Menten-type saturation kinetics and (ii) the rate constants are saturated at around  $[\text{pNPD}]/[\mathbf{1}_6\text{R}] = 1.0$ , suggesting that the pNPD aggregate is broken up into a monomer. The association constants ( $K$ ) and pseudo-first-order rate constants ( $k_{\text{complex}}$ ) for the pNPD·**1**<sub>6</sub>R complexes were determined by a method described previously:<sup>14</sup>  $K = 5.1 \times 10^3$  M<sup>-1</sup> and  $k_{\text{complex}} = 1.5 \times 10^{-3}$  s<sup>-1</sup> for **1**<sub>6</sub>Me and  $K = 7.0 \times 10^3$  M<sup>-1</sup> and  $k_{\text{complex}} = 7.5 \times 10^{-3}$  s<sup>-1</sup> for **1**<sub>6</sub>Oct. The second-order rate constants for the complexes ( $k_{2,\text{complex}} = k_{\text{complex}}/[\text{OH}^-]$ ; 463 M<sup>-1</sup> s<sup>-1</sup> for **1**<sub>4</sub>Me and 2310 M<sup>-1</sup> s<sup>-1</sup> for **1**<sub>6</sub>Oct) are greater by  $(1.2-5.9) \times 10^5$ -fold than that for **1**<sub>4</sub>Me (at 0.001 M).<sup>15</sup>

It is now clear that basic hydrolysis of pNPD can occur by either a "desheilding" or a "host-guest" mechanism. The difference is ascribed to the cavity size and the cavity shape of the calixarenes that were used. Calix[4]arene has a bowl-shaped, narrow cavity.<sup>7,16-20</sup> Thus, the calix[4]arene complexes would not be stabilized

in solution, particularly in water, because the aqueous complexes are formed by hydrophobic force arising from host-guest stacks.<sup>21</sup> In contrast, calix[6]arene has a cavity-shaped stoma suitable for guest-binding.<sup>7,22</sup> This suggests that, in principle, the "hole-size" concept is acceptable in calixarene chemistry. The remarkable rate enhancement observed for **1**<sub>6</sub>R supports the view that the "host-guest" mechanism is more effective than the "desheilding" mechanism for the rapid decomposition of aggregated substrates. This conclusion has important implications for molecular design of biomimetic catalysts which mediate, for example, decomposition of biomembranes, polypeptides, etc.

**Acknowledgment.** This research was supported by a grant from the Ministry of Education of Japan.

(21) Shinkai, S.; Araki, T.; Manabe, O. *J. Am. Chem. Soc.* **1988**, *110*, 7214.

(22) Mckervey, M. A.; Seward, E. M.; Ferguson, G.; Ruhl, B.; Harris, J. *J. Chem. Soc., Chem. Commun.* **1985**, 388.

### Poly(carbophosphazenes): A New Class of Inorganic-Organic Macromolecules

Ian Manners and Harry R. Allcock\*

Department of Chemistry  
The Pennsylvania State University  
University Park, Pennsylvania 16802

Gerhard Renner and Oskar Nuyken\*

Makromolekulare Chemie I, Universität Bayreuth  
Universitätsstrasse 30, D-8580 Bayreuth  
Federal Republic of Germany

Received March 27, 1989

The synthesis of macromolecules that contain inorganic elements in the polymer backbone is currently an area of intense investigation.<sup>1-7</sup> This is a consequence of the need for polymers that have unusual electrical, optical, thermal, or biomedical characteristics or which function as precursors to ceramic materials. In principle, the ring-opening polymerization of cyclic inorganic compounds is an attractive route to new macromolecular species. However, relatively few examples of the successful use of this approach have been reported.<sup>1</sup>

Cyclic phosphazenes such as **1** are some of the best studied examples of polymerizable inorganic ring systems. Thus, many halogeno and organohalogeno cyclotriphosphazenes have been shown to undergo thermal ring-opening polymerization to macromolecules such as **2** with backbones of alternating phosphorus and nitrogen atoms.<sup>1,8-10</sup> Replacement of the halogen atoms in **2** by organic or organometallic units has provided access to a broad

(12) The products were identified by IR, NMR, and elemental analysis. It is known that O-methylation of calix[4]arene derivatives affords conformational isomers because of steric inhibition of the oxygen through the annulus rotation. The <sup>1</sup>H NMR spectrum of tetramethoxy-*p*-nitrocalix[4]arene was very complicated, indicating that this compound consists of a mixture of conformational isomers. In contrast, **1**<sub>4</sub>Me gave a pair of doublets for the ArCH<sub>2</sub>Ar (3.40 and 4.52 ppm in D<sub>2</sub>O at 30 °C), a sign of "cone" conformation.<sup>7,8</sup> Probably, the "cone" isomer was purified through the synthetic route.

(13) For details of the methods, see: Shinkai, S.; Mori, S.; Koreishi, H.; Tsubaki, T.; Manabe, O. *J. Am. Chem. Soc.* **1986**, *108*, 2409.

(14) Shinkai, S.; Minami, T.; Kusano, Y.; Manabe, O. *J. Am. Chem. Soc.* **1983**, *105*, 1851.

(15) The referees of this paper suggest that the remarkable rate acceleration observed for **1**<sub>6</sub>R compounds is caused not only by host-guest-type catalysis but also by deaggregation. As observed for **1**<sub>4</sub>R compounds, the deaggregation effect should be also operative in the **1**<sub>6</sub>R catalysis, and, possibly, the rate acceleration (about 10<sup>2</sup>-fold) may be due to this effect. The fact that plots of  $k_{\text{obsd}}$  vs [**1**<sub>6</sub>R] curve upward indicates, however, that the remarkable rate acceleration is primarily due to the host-guest-type catalysis.

(16) Ungaro, R.; Pochini, A.; Andreetti, G. D.; Domiano, P. *J. Chem. Soc., Perkin Trans. 2* **1985**, 197.

(17) Coruzzi, M.; Andreetti, G. D.; Bocchi, V.; Pochini, A.; Ungaro, R. *J. Chem. Soc., Perkin Trans. 2* **1982**, 1133.

(18) Andreetti, G. D.; Ungaro, G. D.; Pochini, A. *J. Chem. Soc., Chem. Commun.* **1979**, 1005.

(19) (a) Bott, S. G.; Coleman, A. W.; Atwood, J. L. *J. Am. Chem. Soc.* **1986**, *108*, 1709. (b) *Ibid.* **1988**, *110*, 610.

(20) Mckervey, M. A.; Seward, E. M.; Ferguson, G.; Ruhl, B. L. *J. Org. Chem.* **1986**, *51*, 3581.

(1) Allcock, H. R. *Chem. Eng. News* **1985**, 63(11), 22.

(2) *Inorganic and Organometallic Polymers*; Zeldin, M., Wynne, K. J., Allcock, H. R., Eds.; ACS Symposium Series 360; American Chemical Society: Washington, DC, 1988.

(3) Bianconi, P. A.; Weidman, T. W. *J. Am. Chem. Soc.* **1988**, *110*, 2343-2344.

(4) Kanatzidis, M. G.; Huang, S. *J. Am. Chem. Soc.* **1989**, *111*, 760-761.

(5) *Electronic and Photonic Applications of Polymers*; Bowden, M. J., Turner, R., Eds.; Adv. Chem. Ser. 1988; Vol. 218.

(6) Hastings, G. W.; Ducheyne, P. *Macromolecular Biomaterials*, CRC Press: 1984.

(7) Wynne, K. J.; Rice, R. W. *Ann. Rev. Mater. Sci.* **1984**, *14*, 297.

(8) Allcock, H. R. *Phosphorus-Nitrogen Compounds*; Academic Press: New York, 1972.

(9) Allcock, H. R. *Angew. Chem., Int. Ed. Engl.* **1977**, *16*, 147.

(10) *Inorganic and Organometallic Polymers*; Zeldin, M., Wynne, K. J., Allcock, H. R., Eds.; ACS Symposium Series 360; American Chemical Society: Washington, DC, 1988; 250-282.

## Scheme I

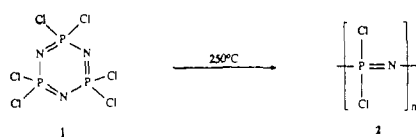

## Scheme II

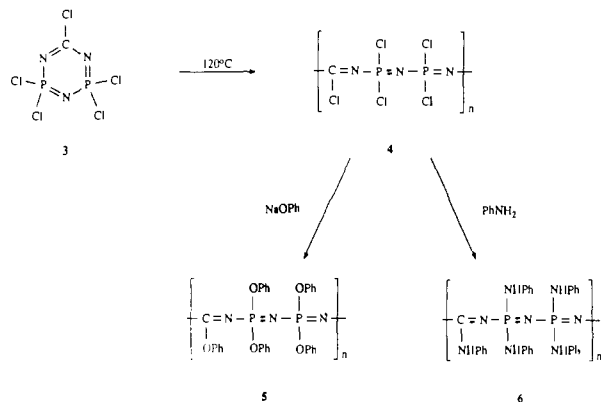

range of stable and useful materials.<sup>1</sup>

We are exploring the possibility that cyclic compounds that contain phosphorus, nitrogen, and a third heteroelement might also polymerize to linear high polymers. Here we report the first ring-opening polymerization of a species (3) that contains a skeletal carbon atom in addition to phosphorus and nitrogen. This provides access to a new class of inorganic-organic macromolecules, the poly(carbophosphazenes).

When the cyclocarbophosphazene 3<sup>11</sup> was heated over a 4-h period in the molten state at 120 °C in an evacuated glass tube, a gradual increase in viscosity was noted. Analysis by <sup>31</sup>P NMR<sup>12</sup> showed that the products consisted of unreacted 3 (ca. 5%) and the poly(carbophosphazene) 4 (ca. 95%). The <sup>31</sup>P NMR spectrum of 4 comprised a singlet resonance at -3.7 ppm which is significantly shifted to high field compared to that of 3 ( $\delta = 36.5$  ppm). A similar shift of the <sup>31</sup>P NMR resonance is observed in the formation of [NPCL<sub>2</sub>]<sub>n</sub> ( $\delta = -18.4$  ppm) from [NPCL<sub>2</sub>]<sub>3</sub> ( $\delta = 19.9$  ppm). The <sup>13</sup>C NMR spectrum of 4 contained a singlet ( $\delta = 154.5$  ppm) assigned to the carbon atoms of the polymer backbone. Because of the sensitivity of 4 to moisture, further characterization was carried out after conversion to the hydrolytically stable aryloxy and amino derivatives, 5 and 6.

Polymers 5<sup>13</sup> and 6<sup>14</sup> were synthesized via the reaction of 4 with excess sodium phenoxide (THF, 25 °C, 12 h) or excess aniline (THF, 50 °C, 96 h), respectively. These macromolecules are stable in the atmosphere. They yield films (5) or glasses (6) that superficially resemble organic polymers. Characterization was achieved by <sup>31</sup>P, <sup>13</sup>C, and <sup>1</sup>H NMR spectroscopy, infrared spectroscopy, elemental analysis, differential scanning calorimetry, and gel permeation chromatography.<sup>13,14</sup> The <sup>31</sup>P NMR spectrum

(11) The white, crystalline cyclocarbophosphazene 3 can be synthesized in four high yield steps from NH<sub>4</sub>Cl, PCl<sub>5</sub>, S<sub>8</sub>, S<sub>2</sub>Cl<sub>2</sub>, and Cl<sub>2</sub> by the method of Fluck et al. (Fluck, E.; Schmid, E.; Haubold, W. *Z. Naturforsch.* **1975**, *30B*, 808-809). In this work typical overall yields were in the region of 35% based on NH<sub>4</sub>Cl.

(12) NMR spectra were recorded in THF (unless otherwise stated) on either a Bruker WP-360 or a JEOL FX-90 Q spectrometer. Chemical shifts are relative to 85% H<sub>3</sub>PO<sub>4</sub> (<sup>31</sup>P), TMS (<sup>1</sup>H), THF-*d*<sub>6</sub>, or CDCl<sub>3</sub> (<sup>13</sup>C).

(13) Compound 3 (1.00 g, 3.4 mmol) was polymerized thermally at 120 °C to afford 4 (95% conversion). Following treatment with excess sodium phenoxide, polymer 5 was isolated as a white, fibrous material after precipitation from THF sequentially into water (to remove NaCl and excess NaOPh) and hexanes (to remove the substituted cyclic trimer 7). Yield of 5 1.32 g (70%). For 5: <sup>31</sup>P NMR  $\delta = 10.4$  s; <sup>1</sup>H NMR (in CDCl<sub>3</sub>)  $\delta = 6.9$  br, s; <sup>13</sup>C NMR (in CDCl<sub>3</sub>)  $\delta = 121.2$  (*o*-PhOP), 122.6 (*o*-PhOC), 123.9 (*p*-PhOP), 124.1 (*p*-PhOC), 128.3 (*m*-PhOC), 129.0 (*m*-PhOP), 151.4 (*ipso*-PhOP), 153.2 (*ipso*-PhOC), 159.8 (NCN) all s; IR 1380 (s,  $\nu$ (C=N)), 1300 cm<sup>-1</sup> (s,  $\nu$ (P=N)); DSC  $T_g = 18$  °C; GPC, single peak,  $M_w = 1.5 \times 10^5$ . Anal. Calcd: C, 64.02; H, 4.34; N, 7.23; Cl, 0.00. Found: C, 63.33; H, 4.15; N, 7.38; Cl, 0.01.

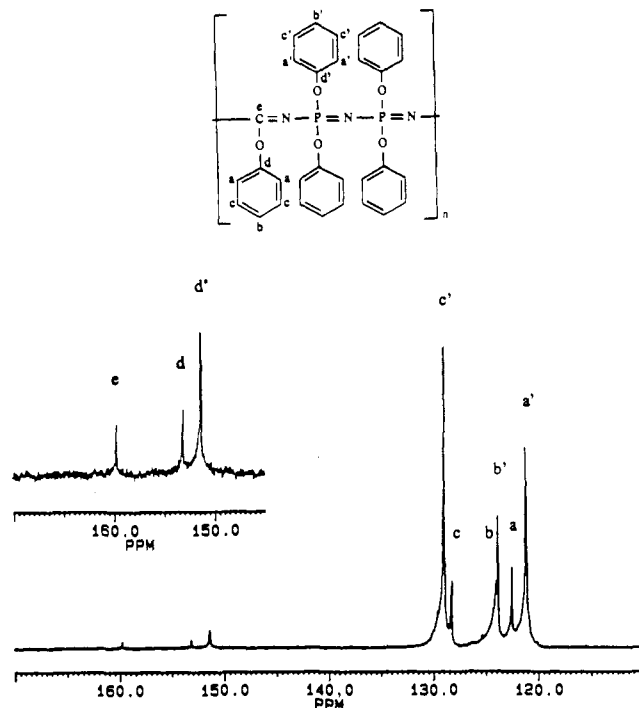

Figure 1. 90.56 MHz <sup>13</sup>C NMR spectrum of 5 in CDCl<sub>3</sub>.

of 5 consisted of a sharp, singlet resonance at -10.4 ppm and that of 6 a broader singlet resonance centered at -9.1 ppm. The <sup>13</sup>C NMR spectra of 5 (Figure 1) and 6 were completely consistent with the assigned structures. In particular, singlet resonances at 159.8 ppm (for 5) and 157.2 ppm (for 6) were assigned to the carbon atoms of the polymer backbone. The infrared spectra of 5 and 6 showed strong absorptions at 1250-1300 and 1400-1480 cm<sup>-1</sup> assigned to skeletal P=N and C=N vibrations, respectively. Differential scanning calorimetry (DSC) indicated a glass transition temperature ( $T_g$ ) of 18 °C for 5 and 112 °C for 6. Interestingly, these values are significantly higher than those of the respective polyphosphazene analogues [NP(OPh)<sub>2</sub>]<sub>n</sub> ( $T_g = -6$  °C)<sup>15</sup> and [NP(NHPh)<sub>2</sub>]<sub>n</sub> ( $T_g = 91$  °C).<sup>16</sup> This suggests that the replacement of a skeletal phosphorus atom by carbon reduces the torsional mobility of the polymer backbone and is consistent with the higher barrier to rotation of a C=N bond compared to that of a P=N bond. Gel permeation chromatography (GPC) confirmed the macromolecular nature of the products and indicated a weight-average molecular weight ( $M_w$ ) of  $1.2 \times 10^5$  for 5 and  $3.1 \times 10^5$  for 6.<sup>17</sup> The syntheses of 5 and 6 were preceded by model reactions at the small molecule level. Thus, reaction of 3 with sodium phenoxide and aniline afforded N<sub>3</sub>P<sub>2</sub>C(OPh)<sub>5</sub>, 7,<sup>18</sup> and N<sub>3</sub>P<sub>2</sub>C(NHPh)<sub>5</sub>, 8,<sup>19</sup> respectively.

The poly(carbophosphazenes) 4-6 represent the first examples of a macromolecular hybrid of poly(phosphazenes), [NPR<sub>2</sub>]<sub>n</sub>, and (the yet unsynthesized) poly(nitriles), [NCR]<sub>n</sub>. In principle, a broad range of polymers of this type should be accessible via replacement of the chlorine atoms of the reactive macromolecular intermediate 4 by other nucleophiles. This approach would take advantage of a methodology well-established in conventional

(14) Polymer 6 was prepared on a similar scale to polymer 5 and was isolated as a white powder after precipitation from THF into hexanes (yield, 55%). For 6: <sup>31</sup>P NMR  $\delta = -9.1$  br, s; <sup>1</sup>H NMR (in CDCl<sub>3</sub>)  $\delta = 6.8$  br, s (Ph), 3.6 br, s (NH); <sup>13</sup>C NMR (in THF-*d*<sub>6</sub>)  $\delta = 118.9$  (*o*-PhO), 121.3 (*p*-PhO), 129.5 (*m*-PhO), 142.0 (*ipso*-PhO), 157.2 (NCN) all br s; IR 3200 (br,  $\nu$ (N-H)), 1390 (s,  $\nu$ (C=N)), 1250 cm<sup>-1</sup> (s,  $\nu$ (P=N)); DSC,  $T_g = 112$  °C; GPC, single peak,  $M_w = 3.1 \times 10^5$ . Anal. Calcd: C, 64.56; H, 5.25; N, 19.44; Cl, 0.00. Found: C, 63.83; H, 5.26; N, 19.09; Cl, 0.48.

(15) Allcock, H. R.; Mang, M. N.; Dembek, A. A.; Wynne, K. J. *Macromolecules*, in press.

(16) Allcock, H. R.; Kugel, R. L. *Inorg. Chem.* **1966**, *5*, 1716.

(17) GPC data was recorded in THF and calibrated against polystyrene. The values of  $M_w$  obtained are considered estimates.

(18) For 7: <sup>31</sup>P NMR  $\delta = 20.2$ ; MS, calcd 581, found 581.

(19) For 8: <sup>31</sup>P NMR  $\delta = 12.5$ ; MS, calcd 576, found 576.

polyphosphazene chemistry,<sup>1</sup> and studies on the synthesis and properties of analogues to 4-6 are in progress.

**Acknowledgment.** This work was carried out at The Pennsylvania State University. We thank the U.S. Army Research Office (H.R.A. and I.M.), Bayer AG, and the F.R.G. Ministry of Science and Technology (O.N. and G.R.) for financial support. We are also grateful to W. D. Coggio and K. Visscher for obtaining high field NMR spectra and DSC data, respectively.

## A Hydridovinyliridium Complex More Stable Than Its $\eta^2$ -Ethylene Isomer

Chanchal K. Ghosh, James K. Hoyano, Richard Krentz, and William A. G. Graham\*

Department of Chemistry, University of Alberta  
Edmonton, Alberta, Canada T6G 2G2

Received March 21, 1989

There is now strong evidence that  $\eta^2$ -benzene intermediates are involved in benzene activation to form complexes such as  $(\eta\text{-C}_5\text{Me}_5)(\text{Me}_3\text{P})\text{Rh}(\text{H})(\text{C}_6\text{H}_5)$ ,<sup>1</sup> a possibility envisaged earlier.<sup>2</sup> It was thus natural to assume that an  $\eta^2$  intermediate would be involved in the activation of olefinic C-H bonds by metal complexes. This notion was upset by the important observation that  $(\eta\text{-C}_5\text{Me}_5)(\text{Me}_3\text{P})\text{Ir}(\eta\text{-C}_2\text{H}_4)$  was more stable than its hydridovinyl isomer  $(\eta\text{-C}_5\text{Me}_5)(\text{Me}_3\text{P})\text{Ir}(\text{H})(\text{CH}=\text{CH}_2)$  and thus could not be an intermediate in formation of the latter.<sup>3</sup> Other examples of this stability order,  $L_n\text{M}(\eta^2\text{-C}_2\text{H}_4) > L_n\text{M}(\text{H})(\text{CH}=\text{CH}_2)$ , have been reported.<sup>1b,4</sup>

In experiments with an iridium complex of a new tris(pyrazolyl)borate ligand, we have encountered a particularly clear case in which this stability order is reversed. The new ligand is the tris(3-(trifluoromethyl)-5-methylpyrazol-1-yl)borato anion, designated  $\text{HBPF}_3^-$  (**1**).<sup>5</sup> The complex is the four-coordinate, 16-

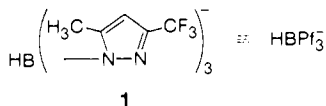

1

electron  $(\eta^2\text{-HBPf}_3)\text{Ir}(\text{CO})(\eta^2\text{-C}_2\text{H}_4)$  (**2**).<sup>7</sup> The bidentate character of the  $\text{HBPF}_3^-$  ligand in **2** follows from a systematic comparison of carbonyl stretching bands of related complexes and is similar to that found in  $(\eta^2\text{-HBPz}^*_3)\text{Rh}(\text{CO})(\eta^2\text{-olefin})$  ( $\text{Pz}^* = 3,5\text{-dimethylpyrazol-1-yl}$ ).<sup>8</sup> At 100 °C in cyclohexane in the dark, **2** goes completely to the hydridovinyl isomer **3**<sup>9</sup> as in eq 1.

(1) (a) Jones, W. D.; Feher, F. J. *J. Am. Chem. Soc.* **1982**, *104*, 4240-4242. (b) Jones, W. D.; Feher, F. J. *J. Am. Chem. Soc.* **1984**, *106*, 1650-1663. (c) Jones, W. D.; Feher, F. J. *J. Am. Chem. Soc.* **1985**, *107*, 620-631. (d) Jones, W. D.; Feher, F. J. *J. Am. Chem. Soc.* **1986**, *108*, 4814-4819. (e) Jones, W. D.; Feher, F. J. *Acc. Chem. Res.* **1989**, *22*, 91-100.

(2) Chatt, J.; Davidson, J. M. *J. Chem. Soc.* **1965**, 843-855. Giannotti, C.; Green, M. L. H. *J. Chem. Soc., Chem. Commun.* **1972**, 1114-1115. Parshall, G. W. *Catalysis (London)* **1977**, *1*, 335-368.

(3) Stoutland, P. O.; Bergman, R. G. *J. Am. Chem. Soc.* **1985**, *107*, 4581-4582; **1988**, *110*, 5732-5744.

(4) (a) Wenzel, T. T.; Bergman, R. G. *J. Am. Chem. Soc.* **1986**, *108*, 4856-4867. (b) Baker, M. V.; Field, L. D. *J. Am. Chem. Soc.* **1986**, *108*, 7433-7434. (c) Baker, M. V.; Field, L. D. *J. Am. Chem. Soc.* **1986**, *108*, 7436-7438.

(5)  $\text{KHBPf}_3$  was prepared by reaction of excess 3-(trifluoromethyl)-5-methylpyrazole<sup>6</sup> with  $\text{KBH}_4$ , slowly raising the temperature to 210 °C.

(6) Nishiwaki, T. *J. Chem. Soc. B* **1967**, 885-888.

(7) Data for **2**: pale yellow solid; IR (*n*-hexane)  $\nu_{\text{CO}}$  2030  $\text{cm}^{-1}$ ; <sup>1</sup>H NMR ( $\text{CD}_2\text{Cl}_2$ , ambient; although the spectrum is invariant to -80 °C, we think a fluxional process makes two of the pyrazole rings equivalent)  $\delta$  2.01 (m, 2 H,  $\text{CH}_2=\text{CH}_2$ ), 2.40 (m, 2 H,  $\text{CH}_2=\text{CH}_2$ ), 2.42 (s, 3 H,  $\text{CH}_3\text{-Pz}^*$ ), 2.51 (s, 6 H,  $\text{CH}_3\text{-PF}$ ), 6.38 (s, 1 H, H-Pf), 6.51 (s, 2 H, H-Pf); <sup>19</sup>F NMR ( $\text{CD}_2\text{Cl}_2$ ,  $\text{CFCl}_3$  reference)  $\delta$  -57.80 (s, 3 F), -60.40 (s, 6 F); MS (16 eV, 150 °C) 708 (32)  $\text{M}^+$ , 680 (100) [ $\text{M-CO}$  or  $\text{C}_2\text{H}_4$ ]<sup>+</sup>, 652 (5) [ $\text{M-CO-C}_2\text{H}_4$ ]<sup>+</sup>. Anal. ( $\text{C}_{18}\text{-H}_{17}\text{BF}_9\text{IrN}_6\text{O}$ ) C, H, N.

(8) Ghosh, C. K.; Rodgers, D. P. S.; Graham, W. A. G. *J. Chem. Soc., Chem. Commun.* **1988**, 1511-1512.

The half-life of the reaction is 4.5 h at 100 °C, and the only product besides **3** is a small amount (<5%) of  $(\text{HBPf}_3)\text{Ir}(\text{CO})_2$ .

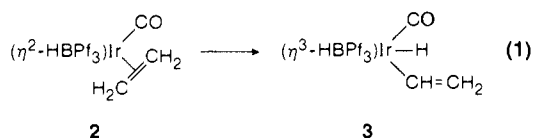

2

3

Recently, Werner et al.<sup>10</sup> have observed that a number of oxygenated vinyl derivatives such as methyl acrylate react with  $\text{Ir}(\text{Cl})\{\text{P}(i\text{-Pr})_3\}_2$  to form an octahedral vinylic hydride **4**,  $\{\text{L} = \text{P}(i\text{-Pr})_3\}$ , evidently via a less stable  $\eta^2$ -olefinic intermediate **5** [ $\text{L} = \text{P}(i\text{-Pr})_3$ ]. Stabilization of **4** relative to **5** was attributed to

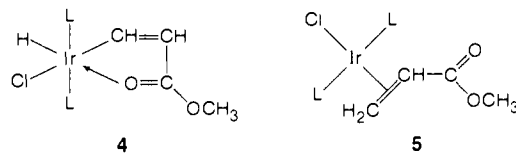

4

5

chelation of the carbonyl oxygen to iridium, resulting in an octahedral, 18-electron complex. The results we have described resemble Werner's, with the notable exception that the sixth ligand comes not from the olefin but from the tris(pyrazolyl)borate group. Isomerization of **2** to **3** amounts to intramolecular C-H activation, and the  $\eta^2$  to  $\eta^3$  change in the  $\text{HBPf}_3^-$  ligand would stabilize the iridium(III) product. It was recently suggested that the intermolecular activation of benzene by  $(\eta^2\text{-HBPz}^*_3)\text{Rh}(\text{CO})(\eta^2\text{-olefin})$  was driven by a similar hapticity increase.<sup>8</sup>

However, the possibility of achieving octahedral coordination is not a sufficient factor to stabilize the hydridovinyl form.<sup>11</sup> A cyclohexane solution of  $(\eta^3\text{-HBPz}^*_3)\text{Rh}(\text{CO})(\text{H})(\text{CH}=\text{CH}_2)$ , **6**,<sup>12</sup> isomerizes at 25 °C in the dark (half-life 3.2 min)<sup>15</sup> to the  $\eta^2\text{-C}_2\text{H}_4$  complex **7**,<sup>16</sup> (eq 2). The contrast in relative stabilities between

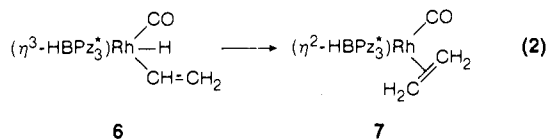

6

7

compounds of the same general class that manifests itself in eq

(9) Data for **3**: colorless, air-stable solid; IR (*n*-hexane) 2259 (w, br,  $\nu_{\text{N-H}}$ ), 2062 (s,  $\nu_{\text{CO}}$ )  $\text{cm}^{-1}$ ; <sup>1</sup>H NMR ( $\text{CD}_2\text{Cl}_2$ , ambient)  $\delta$  -18.23 (s, 1 H, Ir-H), 2.48 (s, 3 H,  $\text{CH}_3\text{-PF}$ ), 2.50 (s, 3 H,  $\text{CH}_3\text{-PF}$ ), 2.55 (s, 3 H,  $\text{CH}_3\text{-PF}$ ), 5.17 (dd, 1 H,  $J = 18$  Hz, 2 Hz,  $\text{CH}=\text{CH}_2$ ), 5.84 (dd, 1 H,  $J = 10$  Hz, 2 Hz,  $\text{CH}=\text{CH}_2$ ), 6.43 (s, 1 H, H-Pf), 6.48 (s, 1 H, H-Pf), 6.52 (s, 1 H, H-Pf), 6.76 (dd, 1 H,  $J = 18$  Hz, 10 Hz,  $\text{CH}=\text{CH}_2$ ); MS (16 eV, 150 °C) 708 (26)  $\text{M}^+$ , 680 (100) [ $\text{M-CO}$  or  $\text{C}_2\text{H}_4$ ]<sup>+</sup>. Anal. ( $\text{C}_{18}\text{H}_{17}\text{BF}_9\text{IrN}_6\text{O}$ ) C, H, N.

(10) Werner, H.; Dirnberger, T.; Schulz, M. *Angew. Chem., Int. Ed. Engl.* **1988**, *27*, 948-950. Both **4** and **5** were isolated, and thermal conversion of the methyl acrylate complex **5** to **4** was directly observed (Professor H. Werner, personal communication).

(11) We do not suggest that it is a necessary factor, even though it is a feature of the two categories presently known where the hydridovinyl isomer is more stable.

(12) Ultraviolet irradiation of  $(\text{HBPz}^*_3)\text{Rh}(\text{CO})_2$  in ethylene-purged cyclohexane at 25 °C produces the very labile<sup>13</sup>  $(\text{HBPz}^*_3)\text{Rh}(\text{CO})(\text{H})(\text{C}_6\text{H}_{11})$ , which reacts rapidly to form a mixture of **6** and **7**. Monitoring at 25 °C of the IR band of **6** at 2048  $\text{cm}^{-1}$  established its first-order disappearance to form **7**. Complex **6** could not be isolated but was characterized as the chloro derivative after treating the mixture with  $\text{CCl}_4$ .<sup>14</sup>

(13) Ghosh, C. K.; Graham, W. A. G. *J. Am. Chem. Soc.* **1987**, *109*, 4726-4727.

(14) Data for  $(\text{HBPz}^*_3)\text{Rh}(\text{CO})(\text{Cl})(\text{CH}=\text{CH}_2)$ : pale yellow crystals; IR (*n*-hexane)  $\nu_{\text{CO}}$  2086  $\text{cm}^{-1}$ ; <sup>1</sup>H NMR ( $\text{CD}_2\text{Cl}_2$ , ambient, 200 MHz)  $\delta$  2.32 (s, 3 H,  $\text{CH}_3\text{-Pz}^*$ ),  $\delta$  2.38 (s, 3 H,  $\text{CH}_3\text{-Pz}^*$ ),  $\delta$  2.40 (s, 6 H,  $\text{CH}_3\text{-Pz}^*$ , accidental degeneracy) 2.46 (s, 3 H,  $\text{CH}_3\text{-Pz}^*$ ), 2.52 (s, 3 H,  $\text{CH}_3\text{-Pz}^*$ ), 5.46 (d, 1 H,  $J = 16$  Hz,  $\text{CH}=\text{CH}_2$ ), 5.71 (d, 1 H,  $J = 7$  Hz,  $\text{CH}=\text{CH}_2$ ), 5.86 (s, 2 H, H-Pz\*, accidental degeneracy), 5.88 (s, 1 H, H-Pz\*), 7.03 (ddd, 1 H,  $J = 16$  Hz, 7 Hz,  $^2J_{\text{Rh-H}} = 3$  Hz,  $\text{CH}=\text{CH}_2$ ).

(15) If the isomerization is carried out with a 30-fold molar excess of benzene, no  $(\text{HBPz}^*_3)\text{Rh}(\text{CO})(\text{H})(\text{Ph})$ <sup>13</sup> is formed. The latter is stable under these conditions, so it follows that the isomerization of **6** to **7** does not proceed by reductive elimination of ethylene followed by its recoordination. The reaction resembles in this way the isomerization of  $(\eta\text{-C}_5\text{Me}_5)(\text{Me}_3\text{P})\text{Ir}(\text{H})(\text{CH}=\text{CH}_2)$  to  $(\eta\text{-C}_5\text{Me}_5)(\text{Me}_3\text{P})\text{Ir}(\eta^2\text{-C}_2\text{H}_4)(\text{CH}=\text{CH}_2)$ ,<sup>3</sup> although the rate in the iridium case is significant only above 180 °C.

(16) Ghosh, C. K.; Graham, W. A. G. *J. Am. Chem. Soc.* **1989**, *111*, 375-376.